

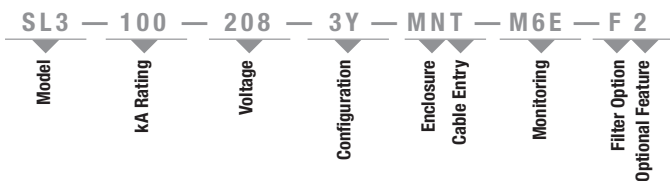

MODEL NUMBER SCHEME (SL3™)

E.g.: SL3-100-208-3Y-MNT-M6E-F2 (as shown in above photo)



kA Rating (Must Choose One)

Available SL3™ kA Ratings:
050, 080, 100, 125, 150, 200,
250, 300

Voltage* (Must Choose One)

208 120/208
240 120/240
380 220/380
480 277/480

Configuration* (Must Choose One)

1G 1-Phase, Grounded
2G 2-Phase, Grounded, Split-Phase
3Y 3-Phase, Grounded, Wye
3R 3-Phase, Grounded, High-Resistance
3H 3-Phase, Grounded, High-Leg Delta
3D 3-Phase, Grounded, Delta

Enclosure (Must Choose One)

MN Metal Without Disconnect
SN Stainless Steel Without Disconnect

Cable Entry (Must Choose One)

T Top Feed
B Bottom Feed

Monitoring (Must Choose One)

M0 No local monitoring
(see remote MxX stand-alone option)
M1 LED/Phase + Audible Alarm,
Dry Relay Contacts
M2 M1 + Surge Counter
M3 Advanced Monitoring,
Character Display, Modbus RTU
M4E M3 + Ethernet, Modbus TCP
M5 Advanced Monitoring,
Graphics Display, Modbus RTU
M6E M5 + Ethernet, Modbus TCP

Filter (Must Choose One)

F Filter
N No Filter

Optional Feature (May Choose One)

2 Test Port

Stand-Alone Options

(To Be Ordered As Separate Items)

DTS DTS-2 Diagnostic Test Set
MxX Remote Monitor Extension
M1X through M6EX
HPI HPI Cable



*See table on back for more Voltage/Configuration Options.

Select® SL3™ suppression filter systems feature selenium-enhanced surge protection along with a powerful failure-free ISM™ (Integrated Suppression Module). The ISM™ contains individual thermally fused and protected MOVs, surge-rated copper busing, robust filtering and advanced remote communications capabilities. Additionally, the SL3's selenium-enhanced seamless technology design ensures maximum performance and a dramatically extended product life.

PRODUCT SPECIFICATIONS

General Specifications

Maximum Surge Current Rating	100kA Per Mode, 200kA Per Phase
Nominal Discharge Surge Current	I-n = 20kA
Safety Listings	UL Listed 1449 4th Edition for Type 1 and Type 2 SPD applications, cUL, and UL 1283 / Meets Requirements for UL 96A / Compliant to IEEE C62.41.1-2002, C62.41.2-2002 and C62.45-2002 / NFPA 70 [NEC], Article 285 / CE, IEC 61643-11-2011 / FCC Part B Class B / EMC Directive 2004/108/EC / Low Voltage Directive 2006/95/EC
Protection Method	Thermally protected MOVs, Selenium, Capacitive Filter
Product Design	Individual thermally fused and protected MOVs, Selenium Cells, and All Copper, Tin-plated Bus
Dimensions	16"H x 16"W x 9.2"D
Weight	43 lbs.
Enclosure Type	NEMA 4/12 Standard (NEMA 4X Option)
Installation Location	Outdoor or Indoor
Operating Environment	-25°C to +60°C 5% – 95% Non-Condensing Humidity
Fault Current (SCCR)	200kAIC
Connection Method	Parallel
Protection Modes	All Modes (L-N, L-G, N-G, L-L)
Response Time	< 0.5 Nanoseconds
Operating Frequency	47 – 63 Hz
Warranty	20 Years

Filtering Attenuation Frequencies (Per Mil-Std-220B January 2000)**

10 KHz	100 KHz	1 MHz	10 MHz	Max at 142 KHz
18.1 dB	44 dB	22.8 dB	15.3 dB	54.6 dB

Single/Repetitive Surge Current Capacities (Tested)**

Protection Mode	Single Pulse Surge Current Capacity/Mode	Repetitive Surge Current Capacity/Mode
Line-to-Neutral	100,000A	14,000 Impulses
Line-to-Ground	100,000A	14,000 Impulses
Neutral-to-Ground	100,000A	14,000 Impulses
Line-to-Line	200,000A	28,000 Impulses
Per Phase	200,000A	28,000 Impulses

Maximum Continuous Operating Voltage (MCOV)

Voltage	L-N MCOV	Voltage	L-L MCOV
120V	150V	240V	300V
277V	320V	480V	552V
347V	420V	600V	690V

** Data based on actual tests. Contact factory for test reports



DIMENSIONAL SPECIFICATIONS

SL3™/100	Inches	(mm)
H1	16.00	(406.4)
H2	17.25	(438.2)
H3	18.50	(469.9)
W1	16.00	(406.4)
W2	10.00	(234.0)
D	9.20	(233.7)

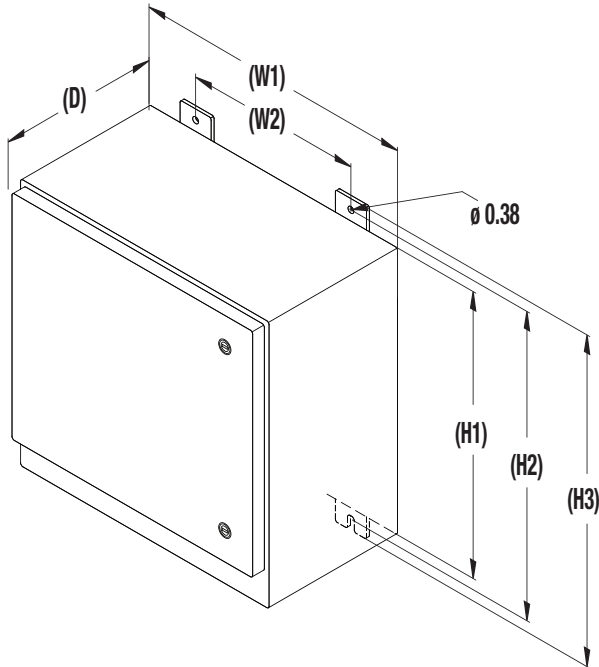

VOLTAGE/CONFIGURATION OPTIONS

Not all voltage configurations are displayed, contact Thomas & Betts Power Solutions for additional configurations.

Voltage	Configuration					
	1G	2G	3Y	3R	3H	3D
120	X					
208	X		X	X		X
220	X	X		X		X
230	X					X
240	X	X			X	X
380		X	X	X		X
415		X	X	X		X
480		X	X	X		X

SL3™/100 PERFORMANCE DATA

System Voltage	120/240V or 120/208V				277/480V				347/600V				240V Delta		480V Delta		600V Delta	
	L-N	L-G	N-G	L-L	L-N	L-G	N-G	L-L	L-N	L-G	N-G	L-L	L-G	L-L	L-G	L-L	L-G	L-L
Protection Mode	L-N	L-G	N-G	L-L	L-N	L-G	N-G	L-L	L-N	L-G	N-G	L-L	L-G	L-L	L-G	L-L	L-G	L-L
MCOV	150	150	150	300	320	320	320	550	420	420	420	690	320	300	552	552	690	690
B3 Ring Wave 6kV, 500A	300	375	350	375	500	825	675	650	570	650	730	680	850	590	1530	660	-	-
B3/C1 Combo Wave 6kV, 3kA	400	400	450	750	850	825	875	1650	1197	1260	1186	2354	1066	964	1604	1824	1260	2354
C3 Combo Wave 20kV, 10kA	600	600	725	950	1125	1050	1175	1925	2080	2200	2140	3390	1830	1960	2460	3020	-	-
UL 1449 4th Edition VPR 6kV, 3kA	700	700	700	1000	1200	1200	1000	2000	1200	1500	1200	2500	1200	1500	1800	2000	3000	2500

All SL3™ systems voltage protection ratings (VPR) are peak values (±10%) measured from the 90° reference point and are in compliance with test and evaluation procedures outlined in ANSI/IEEE C62.41





Energía Verde RMS

Ahorra y contribuye con tu ambiente [®]

General Miguel Barragán #814
Aguascalientes, Ags.
01 (449) 145 2028
energiaverderms.com.mx